

| REVISION HISTORY | | | |
|------------------|-------------|----------|-----|
| REV. | DESCRIPTION | DATE | BY |
| A | As Issued | 06/17/14 | ??? |

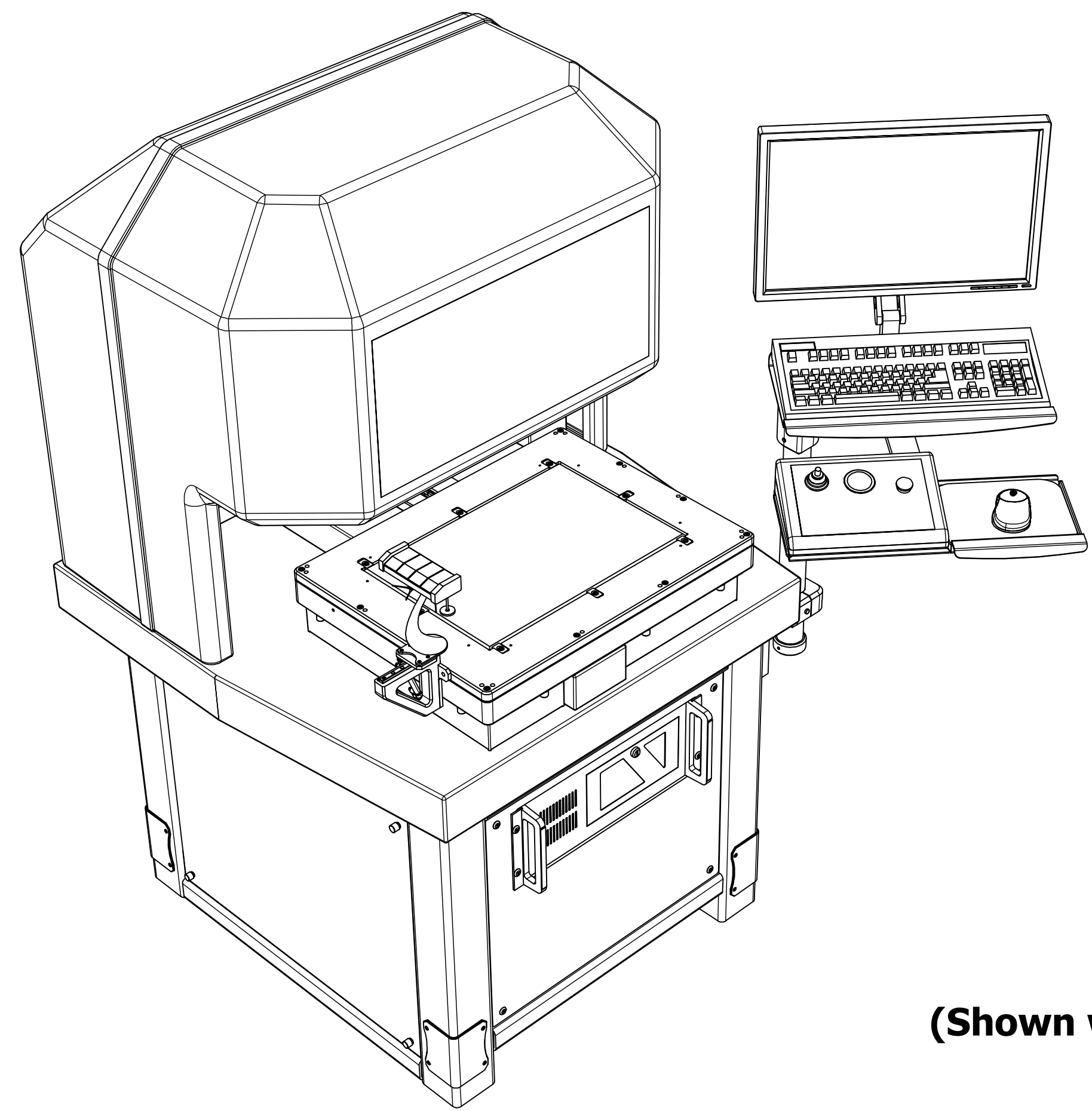

**463 Footprint
(Shown with optional touch probe and probe rack)**

- Options may vary from those shown.
- Typical monitor position shown. Monitor arm height and rotation is adjustable.
- Allow for access to rear and side panels.
- Allow for air and electrical connection at rear of machine.
- Allow 48" top clearance for hood removal.

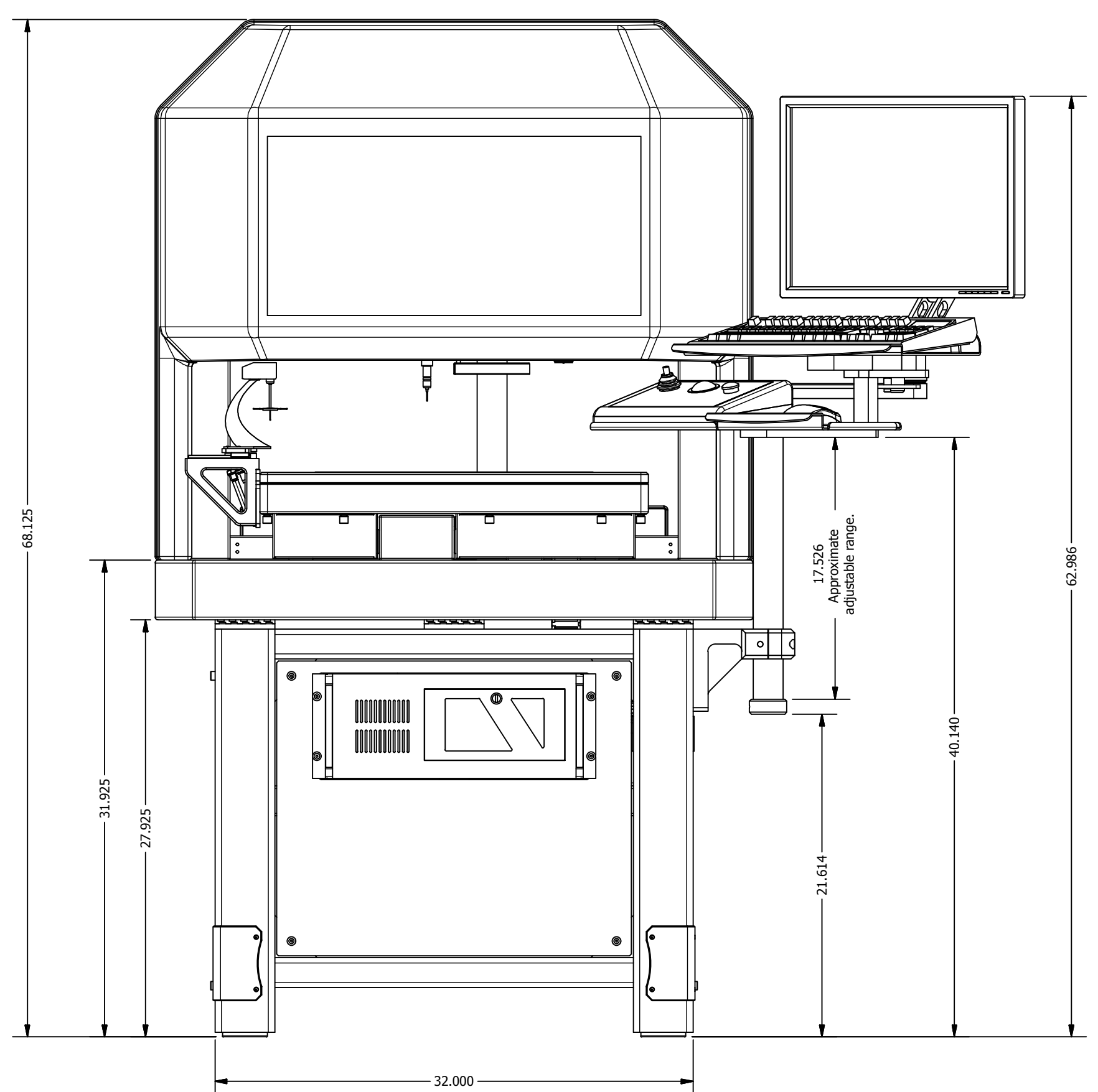
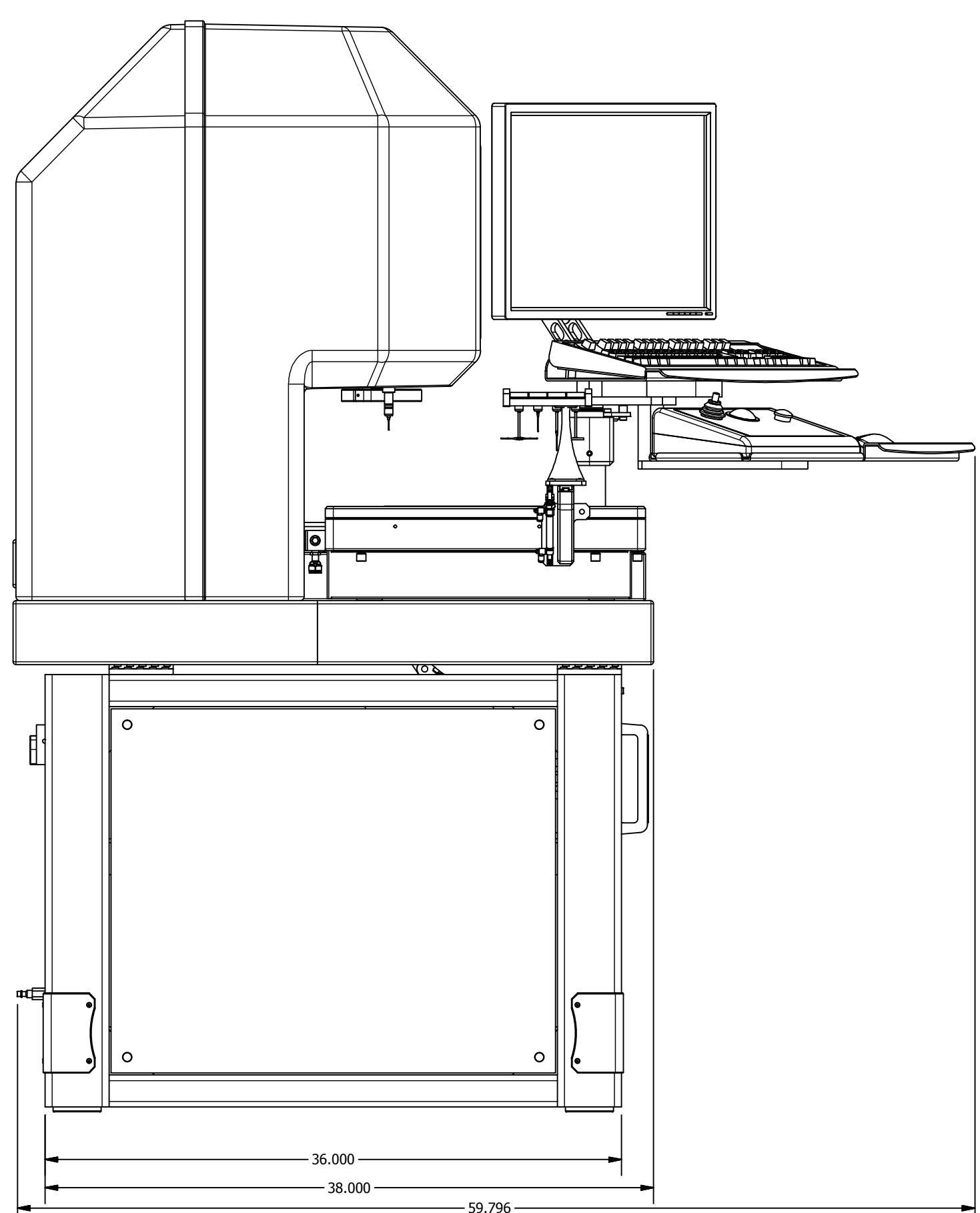
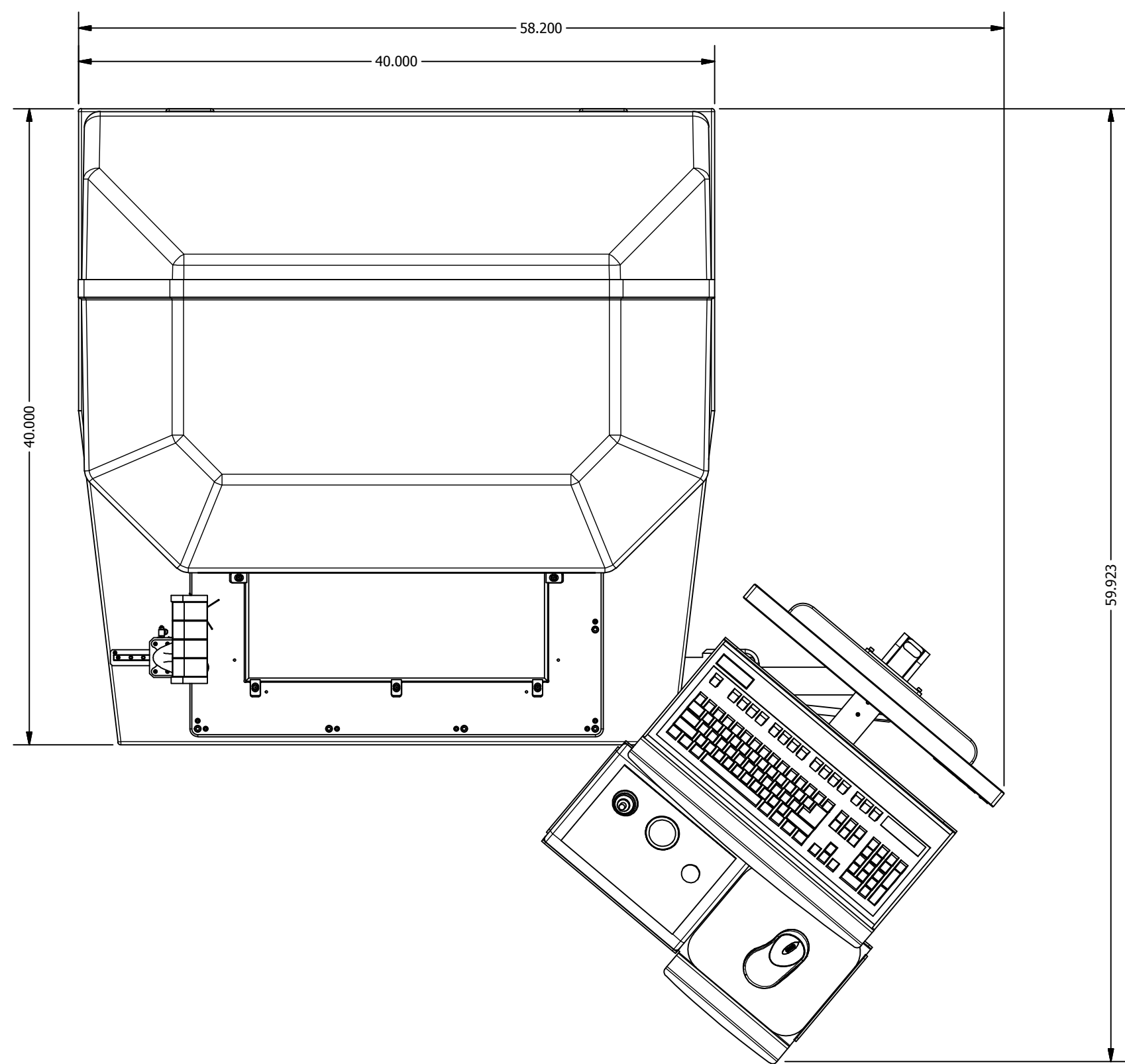

The information in this drawing is the CONFIDENTIAL property of Operations Technology, Incorporated. Disclosure or duplication without prior approval is strictly prohibited.

OPTEK
OPERATIONS TECHNOLOGY INC.
(UNLESS NOTED)

TOLERANCES:
 0.00 [0.0]: ±0.030 [±0.75]
 0.000 [0.00]: ±0.010 [±0.25]
 0.0000 [0.000]: ±0.0010 [±0.025]

UNITS = INCH [MM]

DATE: 6/17/2014 SCALE: 1 : 8 SHEET: 1 OF 1

DESIGN BY: Craig Smigel DRAWN BY: Carl Trubiano

TITLE: Layout, Machine Footprint, 463VSA

DRAWING NUMBER: 7100-3403 REV: A