

REVISION HISTORY			
REV.	DESCRIPTION	DATE	BY
A	As Issued	06/17/14	???

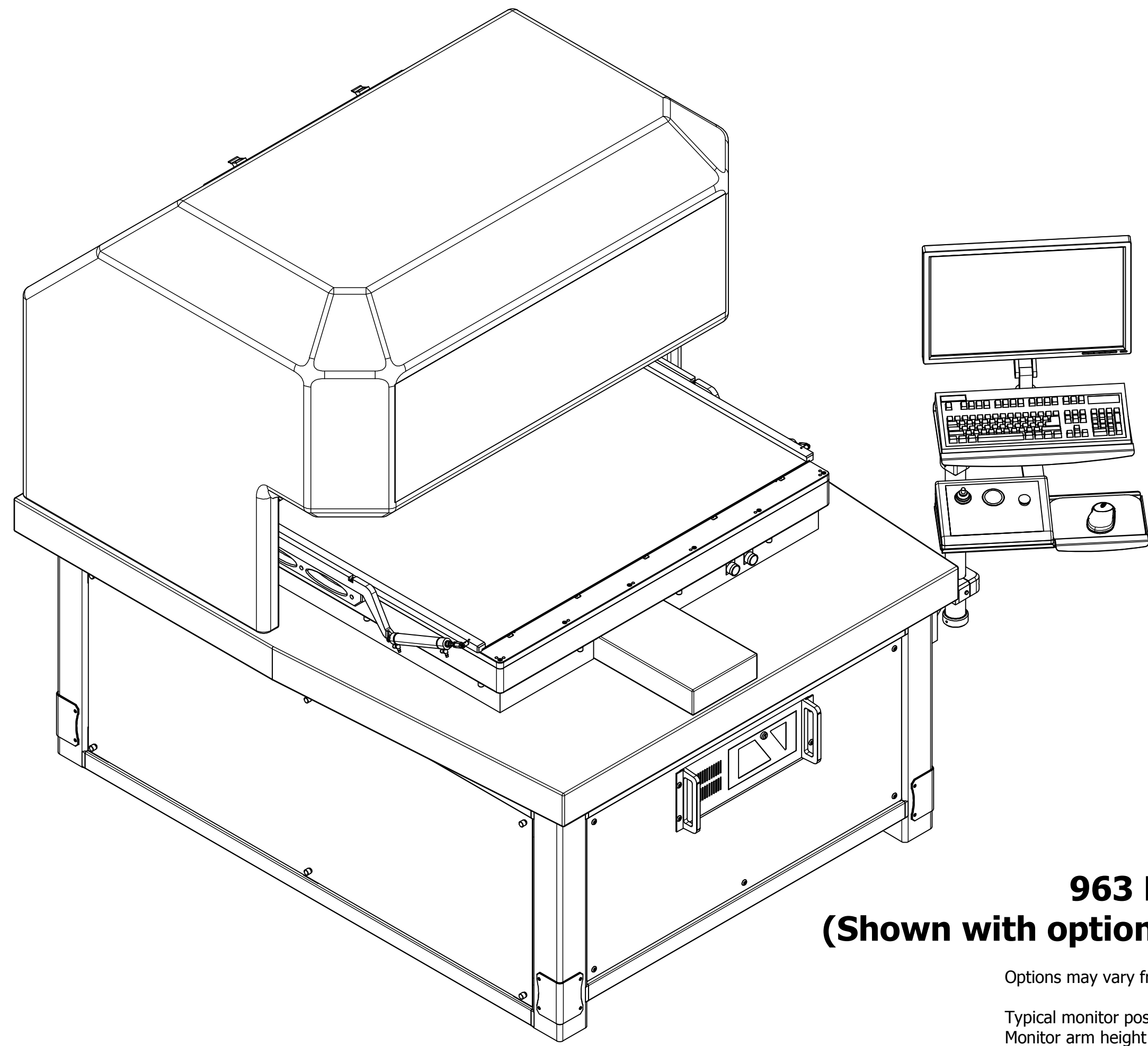

**963 Footprint  
(Shown with optional Hinged Glass Platen)**

Options may vary from those shown.

Typical monitor position shown.  
Monitor arm height and rotation is adjustable.

Allow for access to rear and side panels.

Allow for air and electrical connection at rear of machine.

Allow 52" top clearance for hood removal.

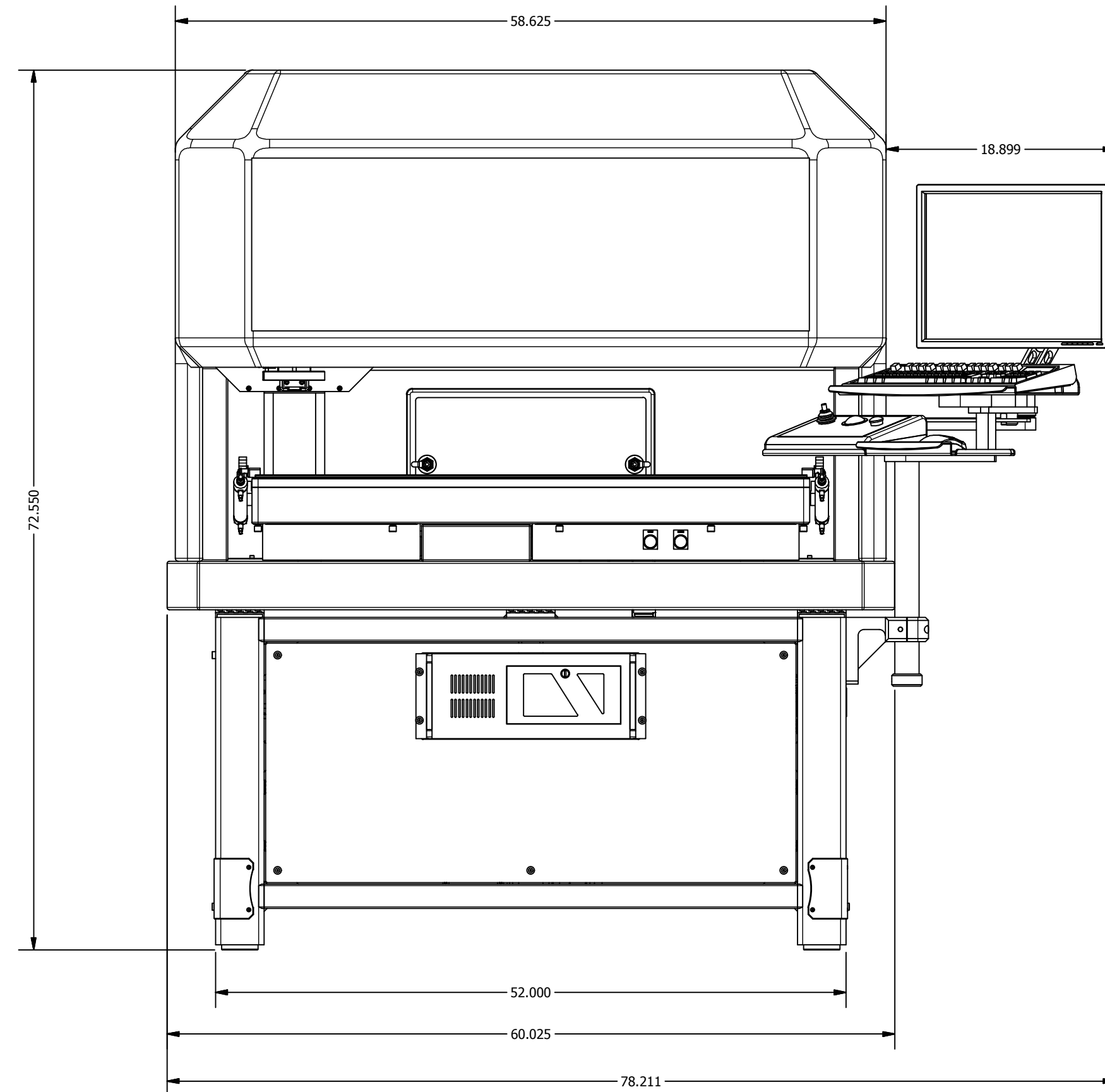
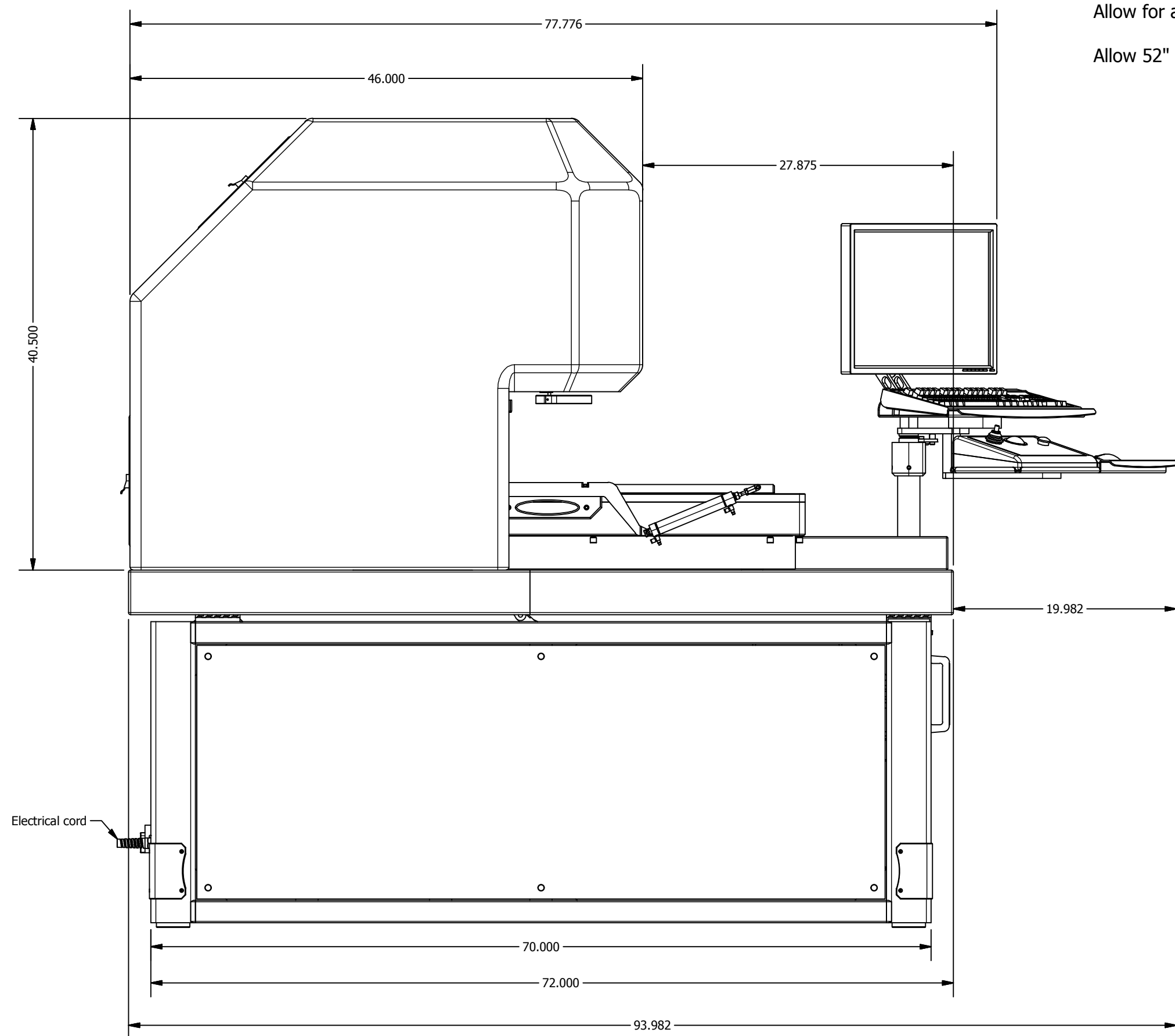
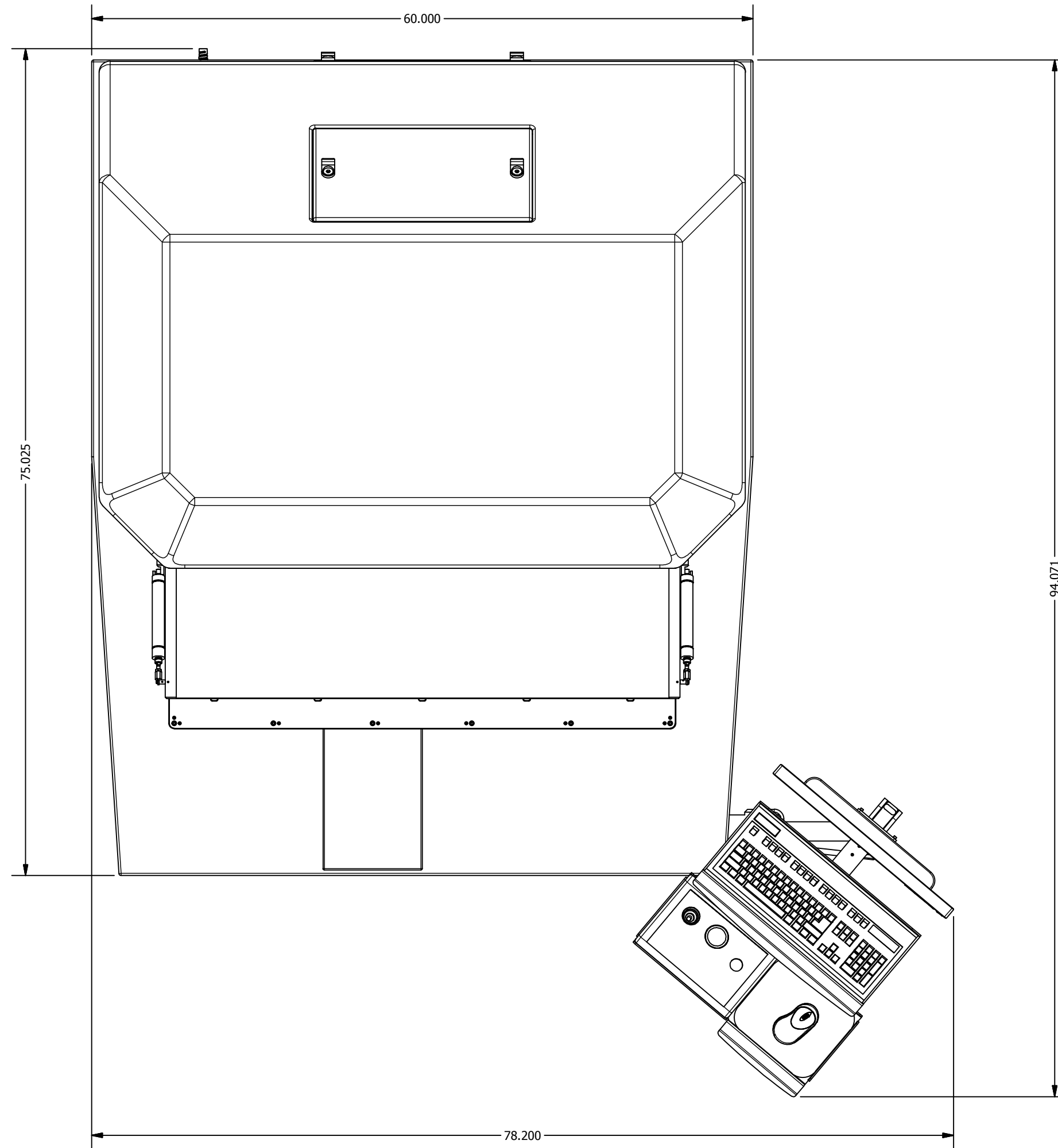

The information in this drawing is the CONFIDENTIAL property of Operations Technology, Incorporated. Disclosure or duplication without prior approval is strictly prohibited.

**OPTEK**  
OPERATIONS TECHNOLOGY INC.  
(UNLESS NOTED)

TOLERANCES: UNITS = INCH (MM)  
0.00 [0.0]: ±0.030 [±0.75]  
0.000 [0.00]: ±0.010 [±0.25]  
0.0000 [0.000]: ±0.0010 [±0.025]

TITLE: Layout, Machine Footprint, 963VSA

MATERIAL:

FINISH:

DATE: 6/17/2014 SCALE: 1 : 10 SHEET: 1 OF 1

DRAWING NUMBER: 7100-3406 REV: A

DESIGN BY: Craig Smigel DRAWN BY: Carl Trubiano